

JVC

SERVICE MANUAL

REMOTE CONTROL UNIT

RM-LP55

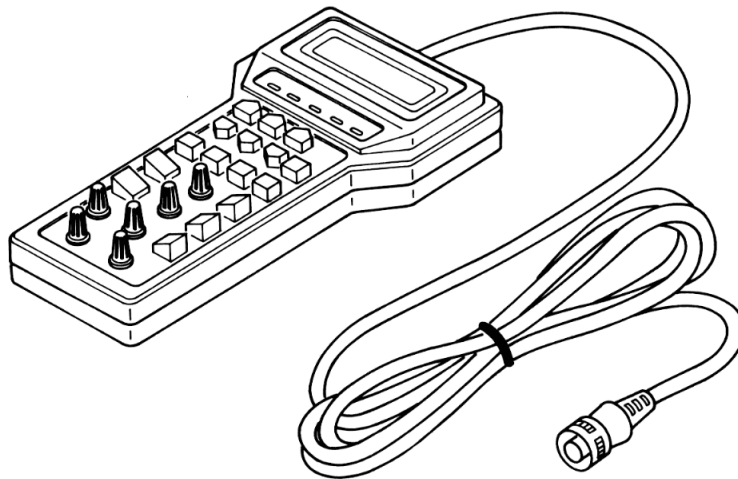

SPECIFICATIONS

- Design and specifications are subject to change without prior notice.
- Dimensions : 95(W) × 198(H) × 34.5(D) mm
- Cable length : 5 m
- Power supply : 9 V DC (supplied from the connected camera)
- Current consumption : 155 mA
- Weight : 400 g
- Ambient temperature range : 0°C to + 45°C

JVC | Instructions

REMOTE CONTROL UNIT **RM-LP55**

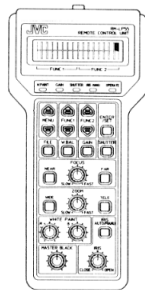

For Customer Use:

Enter below the Serial No. which is located on the rear of the body. Retain this information for future reference.

Model No. RM-LP55

Serial No. _____

Due to design modifications, data given in this instruction book are subject to possible change without prior notice.

WARNING:
TO PREVENT FIRE OR SHOCK HAZARD, DO NOT EXPOSE THIS UNIT TO RAIN OR MOISTURE.

AVERTISSEMENT:
POUR EVITER LES RISQUES D'INCENDIE OU D'ELECTROCUTION, NE PAS EXPOSER L'APPAREIL A L'HUMIDITE OU A LA PLUIE.

POWER SYSTEM

Connection of power supply.
The RM-LP55 is designed for connection to the model KY-F55 Color Video Camera.
Power is supplied from the video camera.

Thank you for purchasing the JVC RM-LP55 Remote Control Unit. To make the most of its many benefits and to ensure correct operation, please read this manual carefully before operating the unit.

The RM-LP55 is a camera remote control unit that can be connected to the JVC KY-F55 3-CCD color camera for remote operation of all major camera functions.(Maximum operating distance is about 5 m.)

CONTENTS

	Page
FEATURES	2
PRECAUTIONS	2
CONTROLS AND OPERATIONS	3
CONNECTIONS	5
OPERATION	5
Operations with the setup menu	6
Operations with mode keys	11
AUTO IRIS LEVEL SETTING	18
FACTORY PRESET MODE SETTINGS	18
SYSTEM RESETTNG	18
SPECIFICATIONS	19

FEATURES

- **Setup Menu function for easy camera preparation**
The RM-LP55's easy-to-use Setup Menu function lets you make all necessary camera settings while referring to the remote's LCD panel.
- **Easy-to-see LCD indications**
Operation status can be displayed on the LCD for at-a-glance checking of current camera settings. The display is backlit so indications are clear and easy to read even in the dark.
- **"Scene File" function**
You can store two different sets of setting data in the remote control's memory which can be called up whenever necessary and applied directly to the connected camera.

PRECAUTIONS

- **Safety precautions**
 - Be sure that no inflammable materials, liquids, or metal objects are introduced into the RM-LP55. This may damage the internal circuitry and lead to failure.
 - Never use the RM-LP55 if it has been modified or the cover has been removed.
 - If the RM-LP55 behaves abnormally (emits strange sounds, odors, or smoke), cut off the power immediately and contact your nearest JVC-authorized service agent.
- **Handling the unit**
 - **Operating environment**
Do not use the unit in places subject to any of the following:
 - vibrations,
 - dust,
 - moisture,
 - smoke or gas.
 - **Ambient temperature:**
Observe the ambient temperature range as described in the Specifications on page 19.
 - **External care of the RM-LP55:**
Gently wipe off dust with a soft dry cloth (such as flannel). If the unit is extremely dirty, dip a soft cloth into a detergent solution diluted with water, wring it thoroughly, then wipe the dirt off. Dry the unit with a dry cloth. Do not use a rag treated with chemicals or allow volatile liquids such as benzene, thinner, alcohol, etc., to come in contact with the RM-LP55. This may mar the finish or damage the coating.

2

CONTROLS AND OPERATIONS

Front & side views with callouts

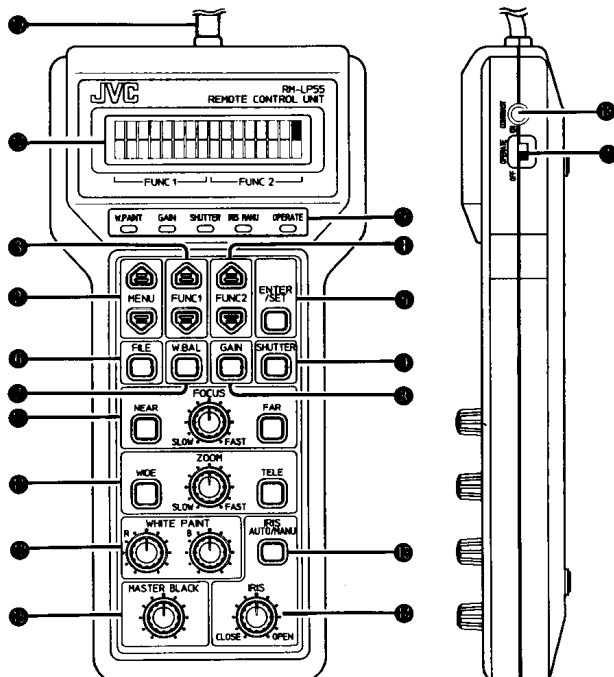

- **[OPERATE] switch**
 - ON : Set to this position to control the camera with the RM-LP55.
 - OFF: Set to this position to disable the RM-LP55's camera control capability.
- **[MENU] buttons**
Calls up Setup Menu items on the LCD panel. The Menu item changes each time the button is pressed. Hold the button depressed to change Menu items in succession.
- **[FUNC1] buttons**
Selects the mode or sets the level for the Setup Menu according to the function of each item.
- **[FUNC2] buttons**
Selects the Setup Menu mode according to the function of each item.
- **[ENTER/SET] button**
This is a multi-function button. Differs from Menu items. (See each item's setting procedure for details.)
 1. During white balance adjustment: Activates auto white balance adjustment.
 2. During title setting: Executes the title setting.
 3. During Scene File operation: Executes the Scene File function.
- **[FILE] button**
Calls up the display for Scene File function.

- 7 **[W.BAL] button**
Calls up the display for white balance adjustment.
- 8 **[GAIN] button**
Calls up the display for gain setting.
- 9 **[SHUTTER] button**
Calls up the display for shutter speed setting.
- 10 **[FOCUS] control with [NEAR/FAR] buttons**
Varies focus control speed. Focus length can be set with the NEAR and FAR buttons.
NEAR : To set focus on a close object.
FAR : To set focus on a distant object.
- 11 **[ZOOM] control with [WIDE/TELE] buttons**
Varies zoom speed. Picture angle can be set with the WIDE and TELE buttons.
WIDE: To set to wide angle.
TELE: To set to telephoto angle.
- 12 **[WHITE PAINT] controls**
 1. Adjusts the R or B channel's gain level when the white balance mode is set to "MANUAL".
 2. When PNT is set to ON with the white balance mode set to "AUTO1" or "AUTO2", these controls are used to vary the R or B channel's gain level for more precise adjustment.
- 13 **[IRIS AUTO/MANU] button**
Switches iris mode between auto and manual.
- 14 **[IRIS] control**
Adjusts the iris while in the manual iris mode. Setting range is from near the CLOSE position to the OPEN position.

Also used for precise adjustment of the auto iris level while in the auto iris mode.

- 15 **[MASTER BLACK] control**
Adjusts the master black level.
- 16 **[LED] indicators**
Light to indicate the current status for each item.
OPERATE : Lights green when the remote control is ready to use.
W.PAINT : Lights amber when the white balance mode is set to "AUTO1" or "AUTO2" with "PNT ON" selected.
GAIN : Lights amber when the gain mode is set to other than "0 dB".
SHUTTER : Lights amber when the shutter mode is set to modes other than "NORMAL". (If the V. SCAN shutter mode is set to "1/60 (1/50 for E version model)", the LED doesn't light.)
IRIS MANU: Lights amber while in the manual iris mode.
- 17 **[LCD PANEL]**
Displays various mode, status, and setting data including Setup Menu, setting mode, setting level, and warning messages.
- 18 **[CONTRAST] control**
Adjusts the LCD's contrast.
- 19 **Cable 5 m**
Connects the remote control unit to a camera.

CONNECTIONS

Connect the RM-LP55 to the KY-F55 (optional color video camera) with the provided cable (5 m). Make sure that the power adaptor connected to the KY-F55 is set to OFF before making any connections.

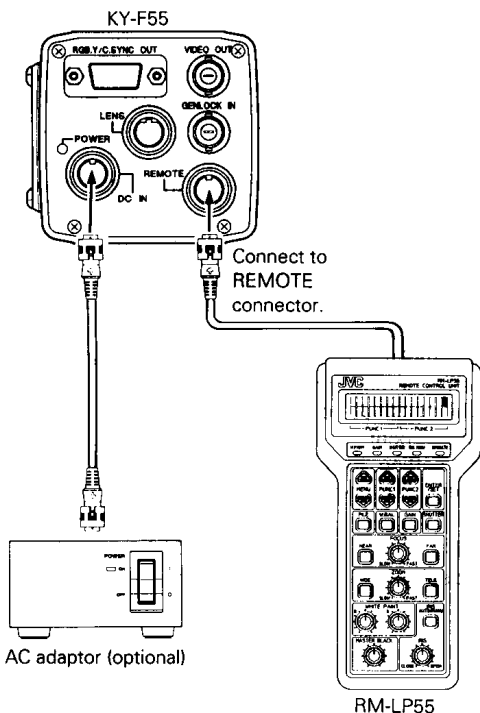

OPERATION

■ ATTENTION:

- Setting data (such as mode or level) entered in the RM-LP55 is stored in its internal memory and held for about 10 days.

1. Make necessary connections (see "CONNECTIONS") and turn on the AC adaptor connected to the KY-F55.
2. Set the OPERATE switch on the side of the RM-LP55 to ON.

- "INITIALIZE" appears on the LCD panel and then changes to "1:CAM MODE". The OPERATE LED will light indicating that the remote control is ready to use.

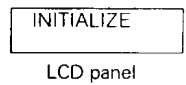

NOTE:

If displayed characters are too light, remove the cap over CONTRAST control then turn it clockwise using a precision screwdriver. If the display is too dark, turn the CONTRAST control counterclockwise.

OPERATIONS WITH THE SETUP MENU

- The setup menu can be accessed via the MENU button and displayed on the LCD panel. Setting items can be selected and set as required.

- Press either MENU button (left or right) to select desired Menu item on the LCD.
- Setting procedure varies for each item. To set data, follow the procedure for each item as described in the following sections.

- There are 8 settable Menu items. They are listed in the chart at right.
- Press to advance to the next item. Press to go back to the previous item.
- After menu item 8, there are no further indications (nothing will be displayed on the LCD panel).

Menu No.	Display
1	1: CAM MODE
2	2: CONTOUR
3	3: SC FINE COARSE
4	4: H. PHASE
5	5: GAMMA
6	6: IRIS DETECT
7	7: TITLE
8	8: TITLE SET



- Press to advance to the next item.
- Press to go back to the previous item.

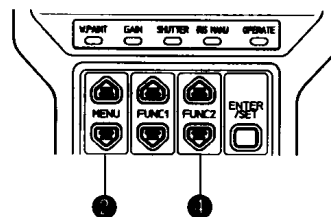

■ CAMERA MODE (CAM/BARS)

- Switches video output between the camera signal and color bars signal.

- Select "1: CAM MODE" using MENU button ②.
- Select output mode, either CAM (camera output) or BARS (color bars signal) using FUNC2 button ④.

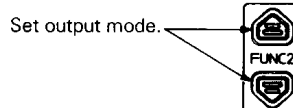
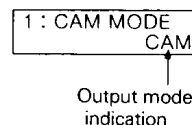

6

OPERATION

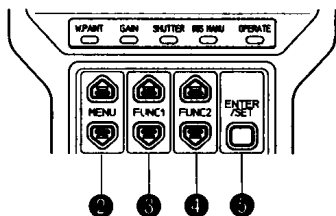

■ CONTOUR MODE (ON/OFF), CONTOUR LEVEL CONTROLS

- Set to ON to correct contour or to OFF when contour correction is not required. When set to ON, the contour correction level can be adjusted within a range of -99 to +99.

- Select "2: CONTOUR" using MENU button ②.
- Set ON or OFF using FUNC2 button ④.
- When set to ON, the current contour level is indicated and the contour level can be adjusted using FUNC1 button ③.

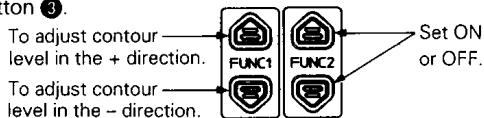
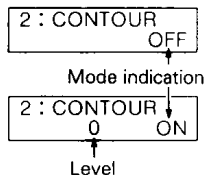

- If the button is held depressed, the level will vary in 10 steps.

■ GENLOCKING MODE ADJUSTMENTS

- Controls SC phase and horizontal phase during genlocking.

- Select "3: SC FINE COARSE" using MENU button ② (SC phase adjustment).

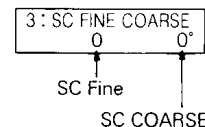

- Set the SC COARSE using FUNC2 button ④ (0°, 90°, 180° and 270°).

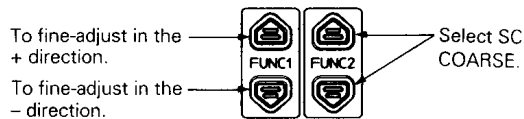

- Fine-adjust the SC phase using FUNC1 button ③ (-128 to +127).

- If the button is held depressed, the level will vary in 10 steps.

- Select "4: H.PHASE" using MENU button ② (horizontal phase adjustment).

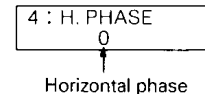

- Adjust the horizontal phase using FUNC1 button ③ (-128 to +127).

- If the button is held depressed, the level will vary in 10 steps.

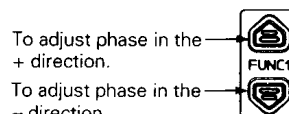

7

■ GAMMA CORRECTION (ON/OFF)

- Set to ON to correct gamma or to OFF when gamma correction is not required.
1. Select "5: GAMMA" using MENU button ②.
 2. Set to ON or OFF using FUNC2 button ④.

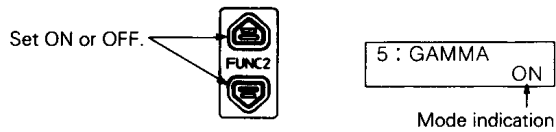

■ AUTO IRIS DETECTION MODE

- Three modes are available:
- NORMAL : Detection is based on a combination of peak value and average value.
- PEAK : The peak value is detected, and the optimum iris level is adjusted.
- AVG : The average value is detected, then the optimum iris level is adjusted.

1. Select "6: IRIS DETECT" using MENU button ②.
 2. Select the detection mode using FUNC2 button ④.
- Each time is pressed, the mode changes from NORMAL → PEAK → AVG → NORMAL → ...; pressing changes the modes in reverse order.

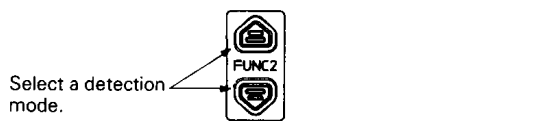

■ TITLE DISPLAY (ON/OFF)

- Set to ON if you want a title display on the monitor screen. Set to OFF if you don't.
1. Press MENU button ② to select Menu item "7: TITLE".
 2. Press FUNC2 button ④ to set the mode to ON or OFF.

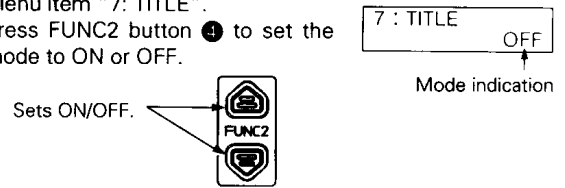

■ TITLE EDIT — Refer to a monitor TV when editing the title.

- To register or correct the title that will be displayed on the monitor TV.
1. Press MENU button ② to select Menu item "8: TITLE SET".
 2. Press FUNC2 button ④ to set the mode to "EDIT".

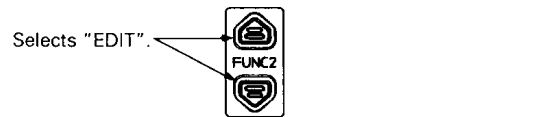

3. Press ENTER/SET button ⑤.
 - (1) The LCD display changes as shown in the figure on the right.
 - (2) The monitor screen shows two windows; the character list window and the title window. The title window displays the current title stored in the camera.

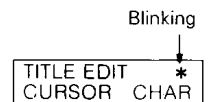

OPERATION

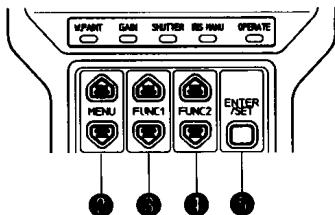

- (3) The first letter in the title will be blinking together with the corresponding letter in the character list window. ("_" blinks in the blank area.)
4. Press FUNC1 button ③ to move the cursor in the title window to select the character to be replaced.
 - Press to move the cursor right and press to move it left. The blinking character in the character list window changes to correspond with the cursor-selected letter in the title window.

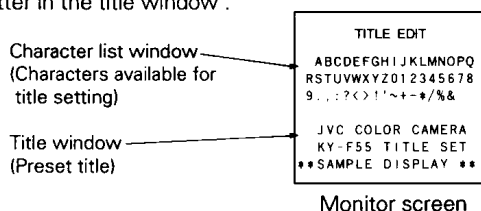
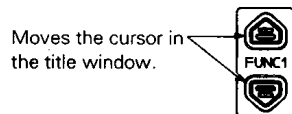

5. Press FUNC2 button ④ to move the cursor in the character list window to select the character to input.
 - Press to move the cursor right and press to move it left. The blinking character in the title window changes to correspond with the cursor-selected letter in the character list window.
6. To set the character, press FUNC1 button ③. The cursor moves and the character in the title window is replaced by the character selected from the character list.
7. Repeat steps 4 — 6 as necessary.
8. Press ENTER/SET button ⑤ to end title setting. The title is stored in the camera's memory.
 - The LCD panel will show "8: TITLE SET".
 - "TITLE EDIT" will disappear from the monitor screen; if the title display function is ON, the title will appear on the monitor screen. If the title display function is OFF, no title will appear.

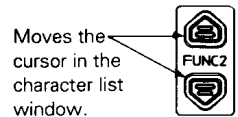

NOTE:
The registered title is not stored in the remote control unit. If you connect a different camera, you'll have to set the title again.

■ TITLE POSITION SETTING — Refer to a monitor when setting the title position.

- Selects the position of the title displayed on the monitor.
1. Press MENU button ② to select Menu item "8: TITLE SET".
 2. Press FUNC2 button ④ to set the mode to "POSITION".
 3. Press ENTER/SET button ⑤.
 - (1) "*" blinks on the top right and the current position value appears on the bottom left of the LCD.
 - (2) The title display background on the monitor screen will reverse and "TITLE POSITION" appears.
 4. While referring to the monitor, move the title display to the desired position by pressing either FUNC1 button ③.
 - Press ▲ to move the title position up and press ▼ to move it down. The value on the LCD changes accordingly. (From 1 to 20; ▲ to increase and ▼ to decrease)

8 : TITLE SET POSITION

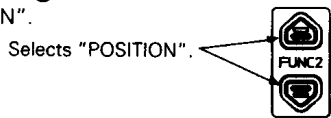

Blinking
8 : TITLE SET *
14 POSITION
Current position

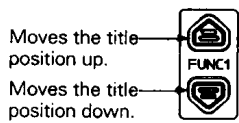
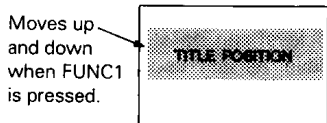

5. Press ENTER/SET button ⑤ to set the position. The title position is stored in the camera's memory.
 - The LCD returns to the Menu item select display (step 1). If Menu item "6: TITLE" is set to "ON", the title will be displayed in the set position.

■ TITLE CLEAR — Refer to a monitor when clearing title data.

- To delete the title data stored in the camera.
1. Press MENU button ② to select Menu item "8: TITLE SET".
 2. Press FUNC2 button ④ to set the mode to "CLEAR".
 3. Press ENTER/SET button ⑤.
 - "*" blinks on the top right of the LCD. "TITLE CLEAR" and the current title appear on the monitor screen.
 4. Press ENTER/SET button ⑤ to delete the title. The title is cleared from the camera's memory.
 - If MENU button ② is pressed instead of ENTER/SET button ⑤, the title clear mode is canceled and the monitor screen returns to normal.

8 : TITLE SET CLEAR

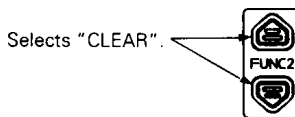

Blinking
8 : TITLE SET *
CLEAR

TITLE CLEAR
JVC COLOR CAMERA
KY-F55 TITLE SET
SAMPLE DISPLAY

Current title (example) Monitor screen

OPERATION

OPERATIONS WITH MODE KEYS

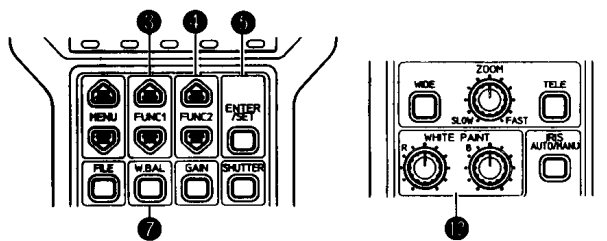

■ WHITE BALANCE MODE SETTING

- To select the camera's white balance mode.
- Available settings**
5 different settings are available.
- PRESET : To set to the preset value (color temperature: 3200 K).
- MANUAL : To set to the value set with the WHITE PAINT controls.
- AUTO1 : To set to the value stored in the camera's auto white balance 1.
- AUTO2 : To set to the value stored in the camera's auto white balance 2.
- FAW : To set to the Full-time Auto White Balance mode for automatic white balance adjustment.
1. Press W.BAL button ⑦.
 - "WHITE BALANCE" appears on the LCD and the current white balance mode is displayed.



WHITE BALANCE PRESET
Current mode

2. Select the white balance mode with FUNC2 button ④.
 - Each time ▲ is pressed, the mode changes from PRESET → MANUAL → AUTO1 → AUTO2 → FAW → PRESET →; pressing ▼ changes the modes in reverse order.

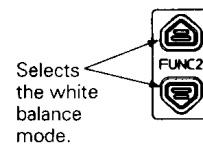

■ WHITE BALANCE ADJUSTMENT

- **Auto white balance adjustment**
1. Set the white balance mode to "AUTO1" or "AUTO2".
 2. Shoot a white subject (white paper, white wall, etc.) so that it fills the whole screen.
 3. Press ENTER/SET button ⑤.
 - "AUTO WHITE 1 (or AUTO WHITE 2) OPERATION" appears on the LCD. The camera's auto white balance mode is activated.
 4. Adjustment ends when "AUTO WHITE 1 (or AUTO WHITE 2) COMPLETED" is displayed on the LCD.
 - The LCD shows "AUTO WHITE 1 (or 2) for about 3 seconds and will return to the Menu item select display (step 1).

WHITE BALANCE PNT OFF AUTO1

AUTO WHITE 1 OPERATION

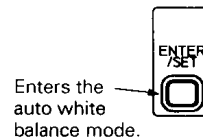

AUTO WHITE 1 COMPLETED

NOTE:

If the LCD shows "COLOR BARS WORKING", cancel the color bar and repeat this procedure. (Auto white balance does not function when the color bars are on.)

COLOR BARS WORKING

● Error Messages

If auto adjustment fails, the procedure stops and one of the following error messages will appear on the LCD.

AUTO WHITE 1
LOW LIGHT ERROR

Light is insufficient.

- Increase the amount of light or increase the gain. (Refer to page 13, "GAIN SETTING")

AUTO WHITE 1
OVER LIGHT ERROR

Light is too strong.

- Make sure strong light such as sunlight is not entering the lens either directly or being reflected by the object the lens is focused on.

AUTO WHITE 1
OBJECT ERROR

The object used for adjustment purposes is not suitable.

- Check to see if the object is too white. (Change the object if necessary.)

NOTE:

- The messages above are displayed for about 3 seconds.
- If "AUTO2" is selected, the display shows an error message below "AUTO WHITE 2".

● White paint adjustment

To adjust the white balance more precisely by varying the B and R channel's gain after auto white balance has been executed.

1. Set the white balance mode to "AUTO1" or "AUTO2". (Refer to page 11 "White balance mode setting".)
2. Set the mode to "PNT ON" with FUNC1 button ③. (W.PAINT LED lights.)

- If "PNT OFF" is selected, the white balance is set to the value obtained by the auto white balance adjustment. (In this case, controls have no effect.)

WHITE BALANCE
PNT ON AUTO1



Selects "PNT ON".

3. Vary the B or R channel level with the WHITE PAINT control ⑫ to adjust the white balance as desired.

NOTE:

If auto white balance is executed with "PNT ON" selected and the procedure is completed properly or fails as "OBJECT ERROR", the setting will automatically switch to "PNT OFF" and the B or R channel level will be restored to the center position value.

● Manual white balance adjustment

To adjust the white balance manually by varying the B or R channel's gain.

1. Set the white balance mode to "MANUAL".
2. Vary the B and R channel levels with the WHITE PAINT controls ⑫ to adjust the white balance as desired.

WHITE BALANCE
MANUAL

NOTE: Function of WHITE PAINT controls ⑫

The last-set WHITE PAINT level can be stored, allowing you to obtain the same level as last used even if the control's position has been changed. However, once the control is turned, the memory is canceled and the level changes to correspond to the control's position.

12

OPERATION

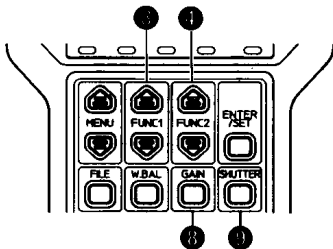

■ GAIN (SENSITIVITY) SETTING

- To select the camera's sensitivity.

Available setting variations

The following 3 settings are possible.
dB mode, ALC + EEI, ALC

1. Press GAIN button ③.
 - The LCD shows "GAIN" with current setting.

GAIN
0dB dB mode

Press GAIN button.



2. Set the gain mode with FUNC2 button ④.
 - Each time ⑫ is pressed, the mode changes from dB mode → ALC + EEI → ALC → dB mode → ...; pressing ⑫ changes the modes in reverse order.
 - In the dB mode, the current gain setting is indicated to the left.
 - If any mode other than "0 dB" is set, the GAIN LED lights.
 - When Gain is set to "ALC + EEI" or "ALC", the iris mode is automatically set to auto iris.

Selects the mode.



3. In the dB mode, select the dB value using FUNC1 button ③.

- Each time ⑫ is pressed, the mode changes from 0 dB → +6 dB → +9 dB → +12 dB → +18 dB; pressing ⑫ changes the modes in reverse order.
- If any mode other than "0 dB" is set, the GAIN LED lights.

GAIN
0dB dB mode

Selects the gain.

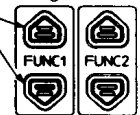

■ SHUTTER MODE (ELECTRONIC SHUTTER) SETTING

- Changes the camera's shutter mode.

Selectable modes

The following 4 MODE can be selected:
NORMAL, STEP, EEI, V.SCAN

1. Press SHUTTER button ⑨.
 - "SHUTTER" and the current shutter mode will be indicated on the LCD screen.

SHUTTER
NORMAL

Press SHUTTER button.



NOTE:

If "GAIN MODE ALC + EEI WORKING" is indicated on the LCD panel, set the gain mode to a mode other than ALC + EEI, then start from the beginning again.

- When set to ALC + EEI, the shutter mode will be fixed at EEI, and you cannot set to any other shutter mode.

GAIN MODE
ALC+EEI WORKING

2. Select the shutter mode using FUNC2 button ④.

- Each time ④ is pressed, the mode changes from NORMAL → STEP → EEI → V. SCAN → NORMAL ...; pressing ④ changes the modes in reverse order.
- In the STEP mode, the current shutter speed is indicated to the left.
- If a shutter mode other than NORMAL is set, the SHUTTER LED lights. (The LED doesn't light if the V. SCAN shutter mode is set to "1/60 (1/50 for E version model)".)

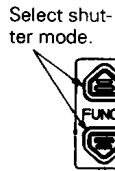

3. In the STEP mode, select the shutter speed using FUNC1 button ③.

- Each time ③ is pressed, the mode changes from 1/100(1/120)* → 1/250 → 1/500 → 1/1000 → 1/2000 → ...; pressing ③ changes the modes in reverse order.

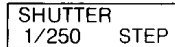

Select shutter speed.

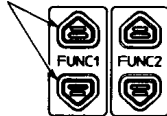

* 1/100 : U-version model
1/120 : E-version model

V. SCAN (VARIABLE SCAN) SETTING

- Varies the camera's shutter speed in sequence so that it can match the scanning speed of a computer monitor display, etc.

1. Select V. SCAN using FUNC2 button ④.

- The current V. SCAN speed be indicated on the LCD screen.

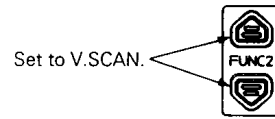
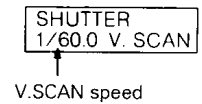

2. Set the V. SCAN speed using FUNC1 button ③ (U-Ver: 1/60.0 to 1/2074.6, E-Ver: 1/50.0 to 1/2061.8).

- The speed can be varied in either the + or - direction using the ⑤ or ⑥ button.
- If the button is kept depressed, the speeds will change faster.

To vary speed in the + direction.

To vary speed in the - direction.

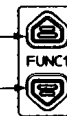

OPERATION

■ LENS CONTROL

- Controls the focus and zoom operations of the HZ-610MD mounted on the camera.

NOTE:

With variable focal lens such as the HZ-G6350, neither zoom nor focus can be controlled.

1. Focus control

If FAR is held depressed, the lens' focal point will be farther away; if NEAR is held depressed, the lens' focal point will be nearer.

- The speed of focus operation can be controlled with the FOCUS control. Turn towards FAST for faster focusing, and to SLOW for slower focusing.

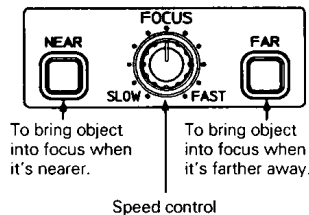

Speed control

2. Zoom control

If TELE is held depressed, the lens' picture angle narrows (telephoto angle); if WIDE is held depressed, the lens' picture angle widens (wide angle).

- The speed of zoom operation can be controlled with the ZOOM control. Turn toward FAST for faster zooming, or to SLOW for more gradual zooms.

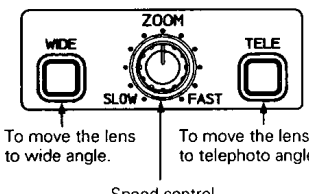

Speed control

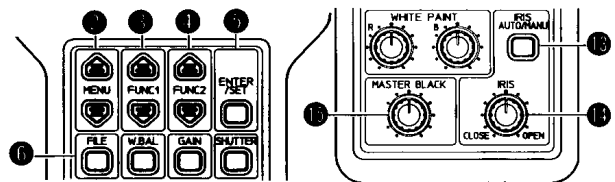

■ LENS IRIS CONTROL

- Operates the iris of the lens mounted on the camera.

Auto iris

1. Press IRIS AUTO/MANU button ⑬ to set to the auto iris mode (the IRIS MANU LED is not lit).
2. Using IRIS control ⑭, adjust the auto iris level. If the control is set to the center position, the level will be standard. (Refer to "AUTO IRIS LEVEL SETTING" on page 18.)
 - If the camera's LENS switch is set to "MANU", the auto iris will not function.

Switch between auto and manual.

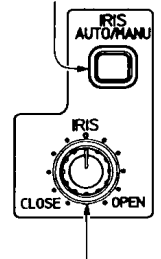

Auto iris mode: serves as a precise auto iris level control.
Manual iris mode: serves as an iris level control.

Manual iris

1. Press IRIS AUTO/MANU button ⑬ and set to the manual iris mode. (The IRIS MANU LED is lit.)
2. Using IRIS control ⑭, the iris level can be controlled (between near CLOSE position and OPEN position).
 - When Gain is set to "ALC + EEI" or "ALC", or when the shutter mode is set to "EEI", the iris mode is automatically set to auto iris. In this case, manual iris operation is not possible.

■ MASTER BLACK LEVEL CONTROL

- Controls the black level of the camera signal.
- Use the MASTER BLACK control **15** to adjust the black level.
- Turn clockwise to increase the black level; turn counterclockwise to decrease the level.

■ SCENE FILE FUNCTION

- To store setting data in the Scene File (A/B) or to call up data stored in the Scene File (A/B) and apply it to the connected camera.

Writing data into Scene File

1. Press FILE button **6**.
 - The "FILE" screen will appear on the LCD.

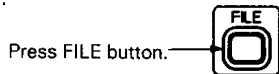

2. Press FUNC1 button **3** to select either SCENE A or SCENE B.
 - Select either the SCENE A or SCENE B.



3. Press FUNC2 button **4** to select "WRITE".

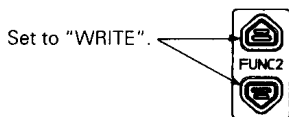

4. Press ENTER/SET button **5**.
 - The LCD shows "SCENE FILE A (or B) WRITE OK?".
5. Press ENTER/SET button **5** again if it's OK.
 - The LCD changes to "SCENE FILE A (or B) WRITING!". The setting data is stored in memory.
 - If you don't want to execute writing, press MENU button **2** to cancel.

SCENE FILE A
WRITE OK?

SCENE FILE A
WRITING!

Reading data from SCENE FILE

1. Press FILE button **6**.
 - The "FILE" screen will appear on the LCD.

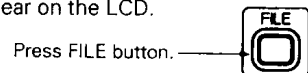

2. Press FUNC1 button **3** to select either SCENE A or B.

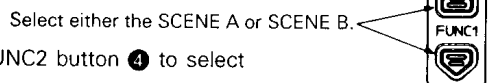

3. Press FUNC2 button **4** to select "READ".

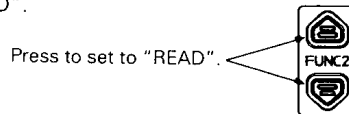

OPERATION

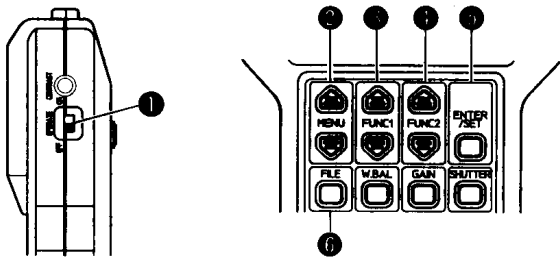

4. Press ENTER/SET button **5**.
 - The display changes to "SCENE FILE A (or B) READ OK?".
5. Press ENTER/SET button **5** again if it's OK.
 - The LCD changes to "SCENE FILE A (or B) READING!". The stored data is read out to the camera.
 - If you don't want to execute reading, press MENU button **2** to cancel.

SCENE FILE A
READ OK?

SCENE FILE A
READING!

NOTE:

The following data cannot be stored in the Scene File. Reset the data as necessary after the Scene File reading.

- Position and speed of zoom/focus
- While balance data set by auto white balance adjustment
- Title data
- Manual iris level
- Auto iris level
- Master black level

■ CAMERA SETUP FUNCTION

- To transfer the data set with the remote control to the camera. The data remains in the camera even when the remote control is disconnected. (Use this function to set up the camera.)

NOTE:

When using the camera in the modes set with the remote control unit, the camera's DATA switch must be set to REMOTE. (Refer to the camera's instructions for details.)

1. Press FILE button **6**.
 - The "FILE" screen will appear on the LCD.
2. Press FUNC1 button **3** to select "RM DATA TO CAM".
 - Press to select "RM DATA TO CAM".
3. Press ENTER/SET button **5**.
 - The display changes to "RM DATA CAM SAVE OK?".
4. Press ENTER/SET button **5** again if it's OK.

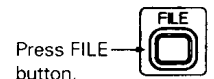

FILE
RM DATA TO CAM

RM DATA TO CAM
SAVE OK?

RM DATA TO CAM
SAVING!

- The LCD panel displays "RM DATA TO CAM SAVING". The setting data is stored in camera's memory.
- If you don't want to execute saving, press MENU button **2** to cancel.

AUTO IRIS LEVEL SETTING

AUTO IRIS LEVEL SETTING

- If auto iris level adjustment using the iris control is not necessary in the auto iris mode, set this to OFF (usually set to ON).

Setting method

- While pressing ENTER/SET (5), set OPERATE switch (1) to ON.

AUTO IRIS LEVEL
ON

 - The auto iris level setting screen will appear on the LCD panel.

- To use the auto iris level, select ON using the FUNC2 button (4). Otherwise, select OFF.

Select either ON or OFF.

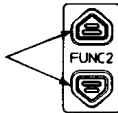

- When settings are complete, press ENTER/SET button (5).
 - "INITIALIZE" appears on the LCD screen, then the unit returns to its normal operating state.

FACTORY PRESET OF MODE SETTINGS

- The default values (factory preset) for each of the RM-LP55's modes are shown below.

Mode	Factory preset	Mode	Factory preset
CAM MODE	CAM	TITLE	OFF
CONTOUR	ON	TITLE POSITION	1
CONTOUR LEVEL	0	SHUTTER	NORMAL
SC COARSE	0°	V. SCAN	1/60.0 (U-ver.)
SC FINE	0		1/50.0 (E-ver.)
H. PHASE	0	GAIN MODE	0 dB
GAMMA	ON	WHITE BALANCE	AUTO1
IRIS DETECT	NORMAL	PAINT	OFF

Any setting data which is currently displayed on the LCD can be reset to the default value (shown in the table above) by pressing the FUNC1 button (3) and the FUNC2 button (4) simultaneously.

You can also simultaneously reset all settings to the default values as described in the next section.

System resetting method

- While pressing the MENU (6) and (7) buttons (2) simultaneously, set the OPERATE switch to ON.

SYSTEM RESET
- "SYSTEM RESET" appears on the display, then the unit returns to its normal operating state.
- System resetting does not affect scene files (A and B) or current camera settings.
- The auto iris level cannot be reset by the system resetting. (Refer to page 18, "AUTO IRIS LEVEL SETTING".)

While pressing these simultaneously, set OPERATE to ON.



18

SPECIFICATIONS

SPECIFICATIONS

- Design and specifications are subject to change without prior notice.

Power supply	: 9 V DC (supplied from the connected camera)
Current consumption	: 155 mA
Weight	: 400 g
Ambient temperature range	: 0°C to +40°C

Dimensions (unit: mm):

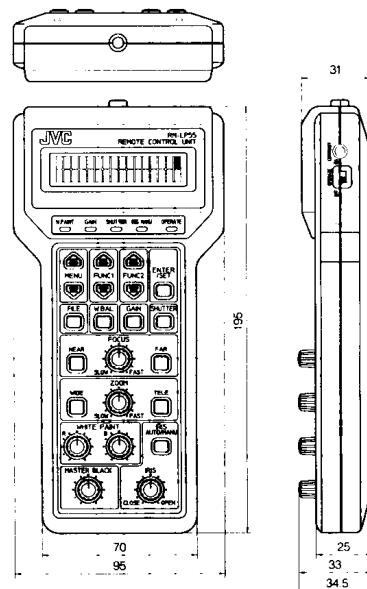

SECTION 1

SCHEMATIC DIAGRAM AND CIRCUIT BOARD

1.1 RM CIRCUIT BOARD

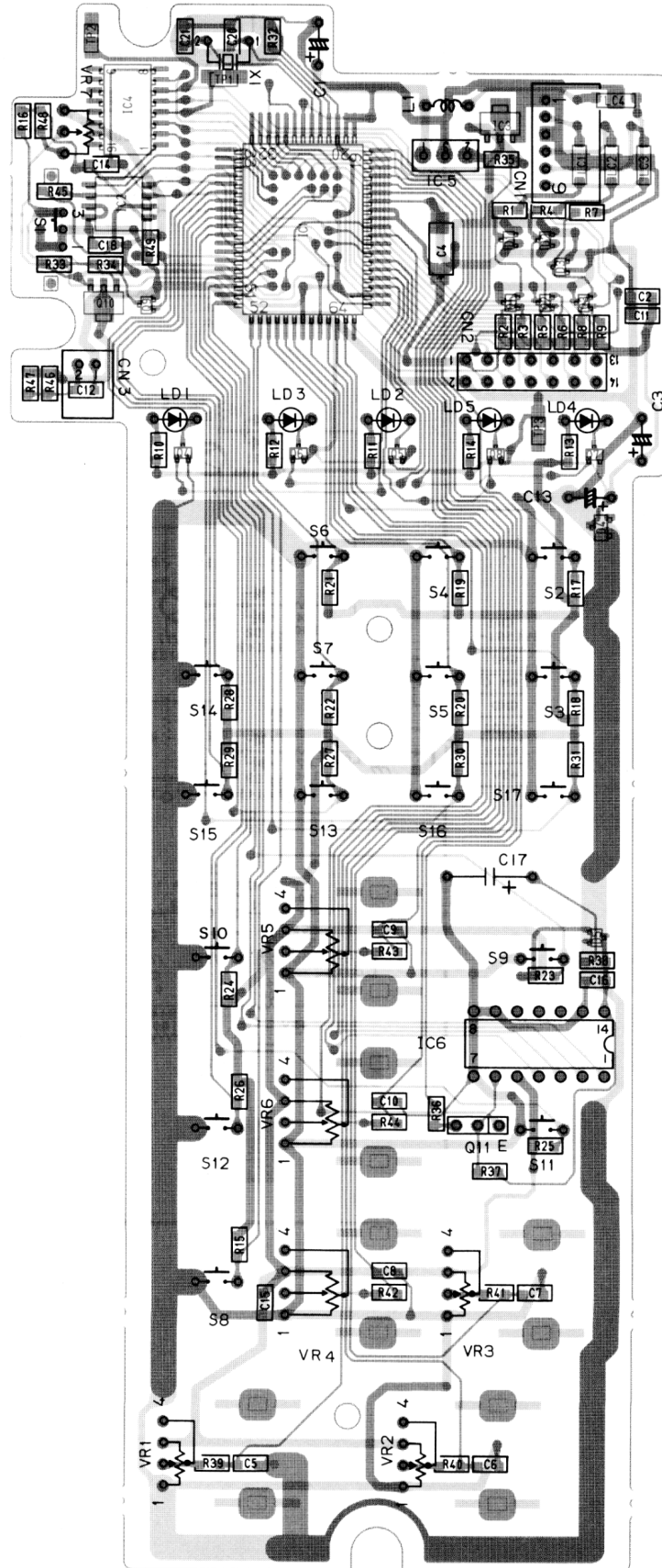

1.2 RM CIRCUIT DIAGRAM 0 1
 (Remote Control Circuit)

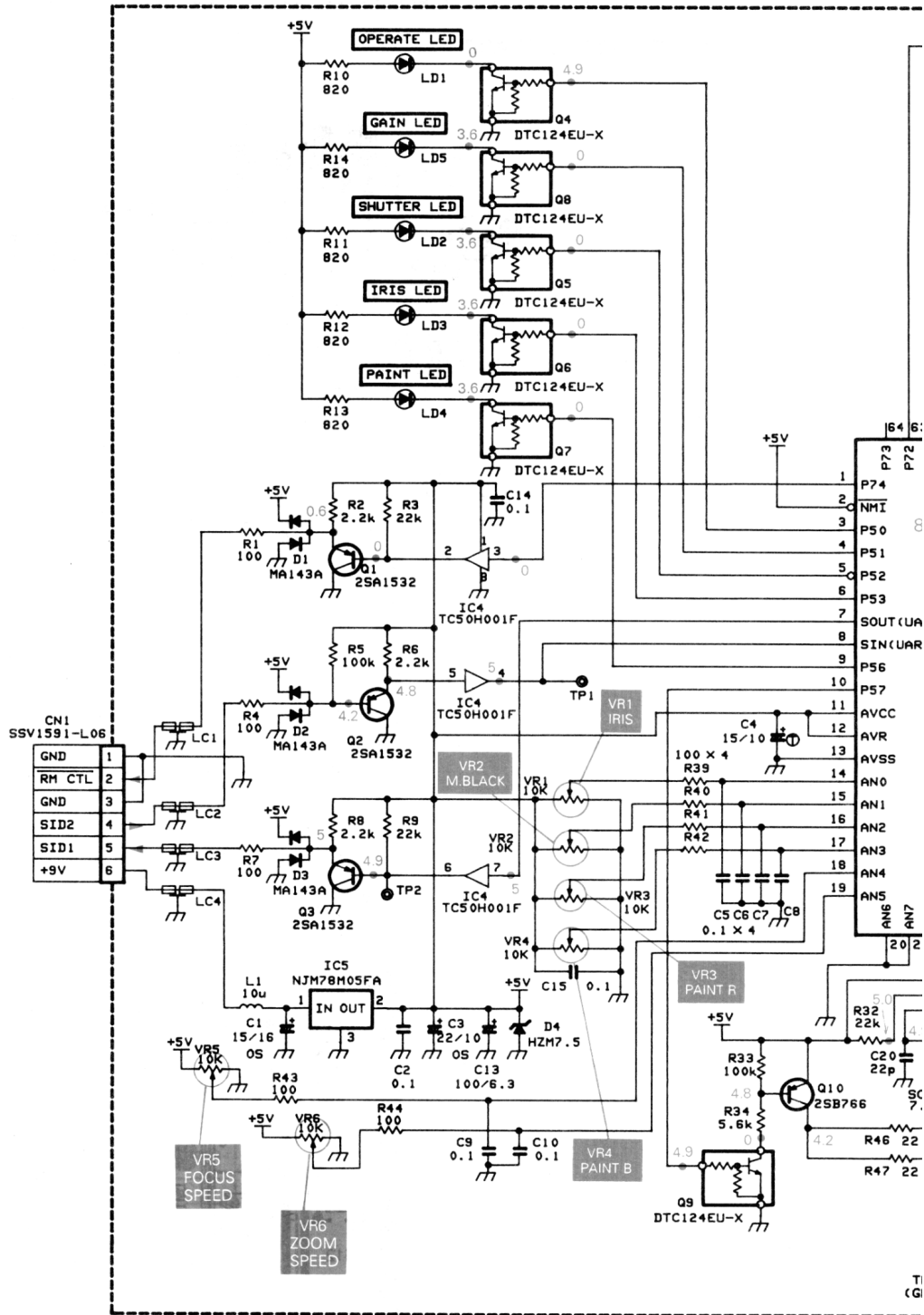

VR1-6 QVGA14B-S14

VR7 QVPB612-103Z

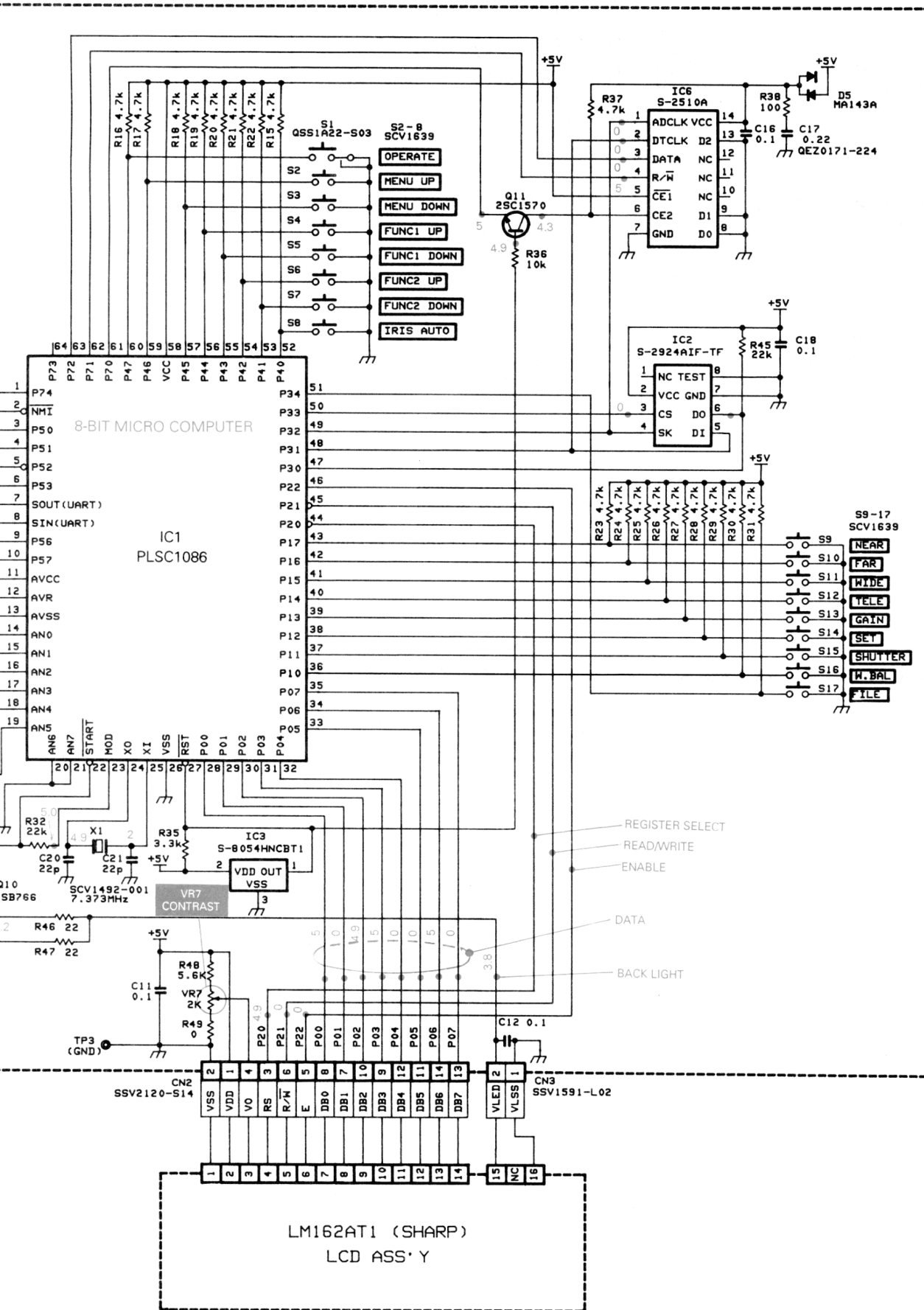

1.3 SCHEMATIC DIAGRAMS OF ICs

■ MB89P718AHPF [FUJITSU] (PROM/EPROM)

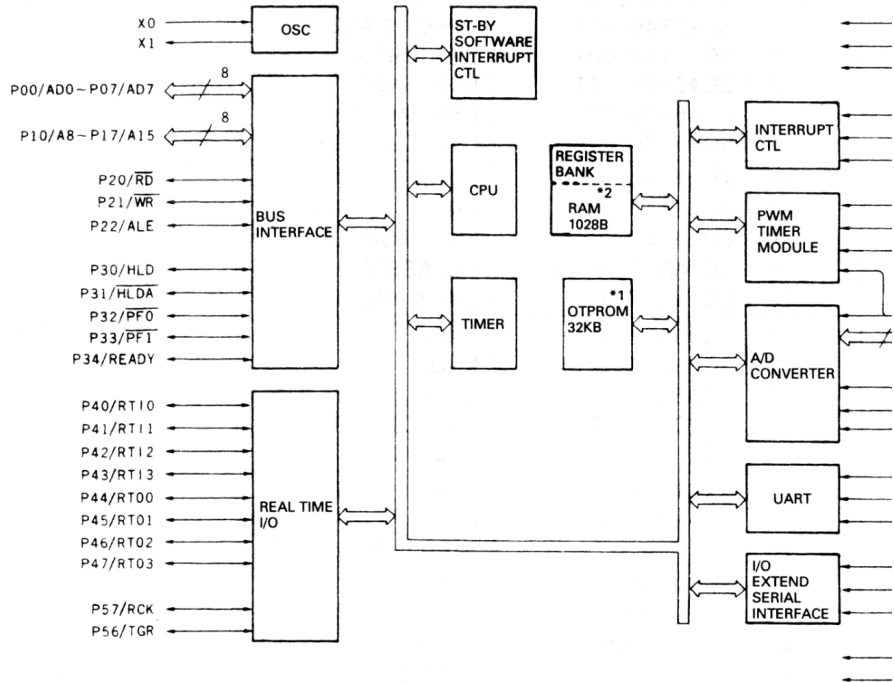
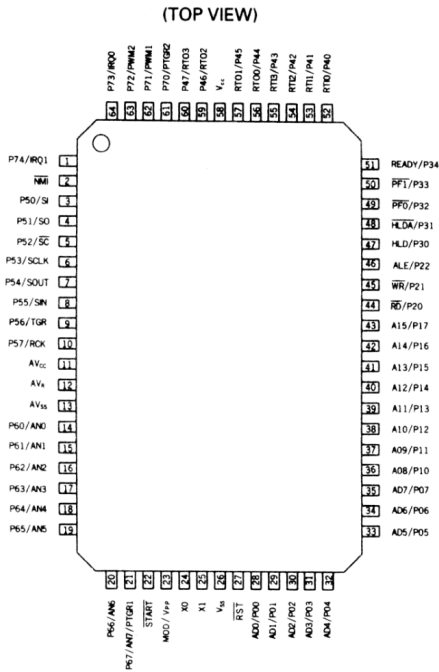

■ NJM78M05FA [JRC] (3-Terminal Positive Voltage Regulator (+5V))

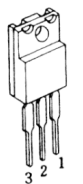

NJM7800FA

1. OUT
2. GND
3. IN

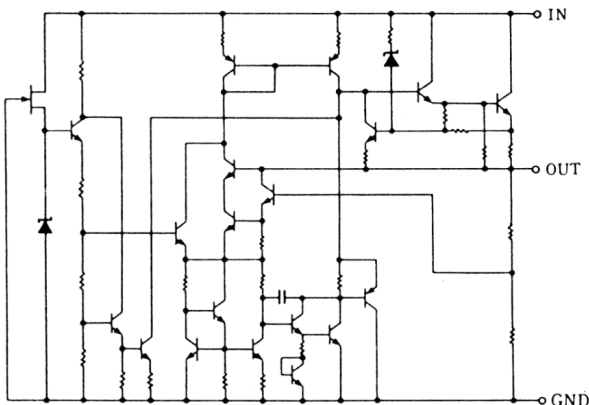

■ S-2924AIF10 [SEIKO INSTRUMENTS] (CMOS 2K-bit Serial EE PROM)

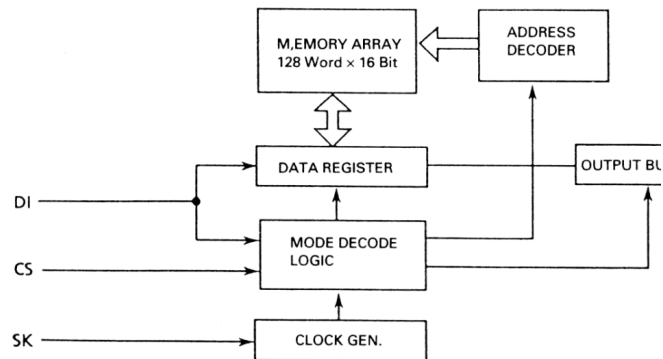
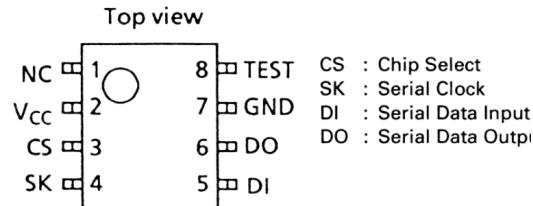

■ S-2510A [SEIKO]
(CMOS 2560 Bit Static RAM)

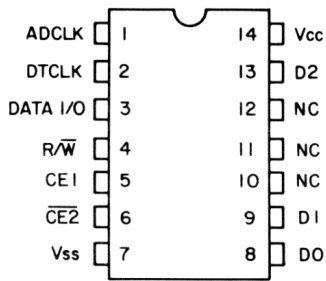

ADCLK	ADDRESS CLOCK
DTCLK	DATA CLOCK
DATA I/O	DATA INPUT/OUTPUT
R/W	READ/WRITE
CE 1	CHIP ENABLE 1
CE 2	CHIP ENABLE 2
NC	NO CONNECT
DO, D1, D2	DATA INPUT SELECT

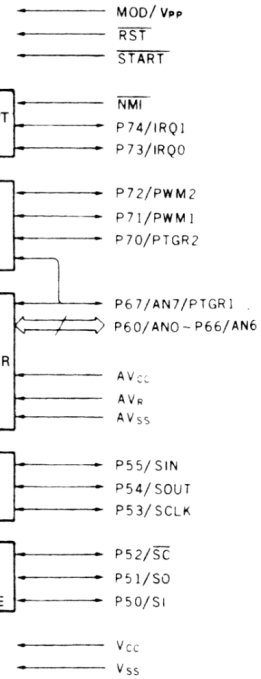
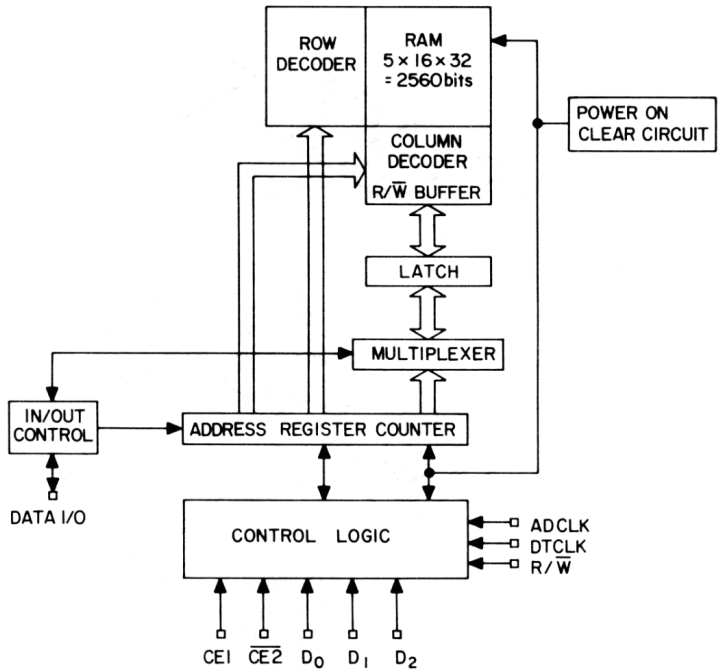

■ S-8054HNCB [SEIKO INSTRUMENTS]
(C-MOS Voltage Detector)

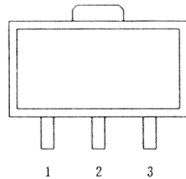

1. OUT
2. VDD
3. VSS

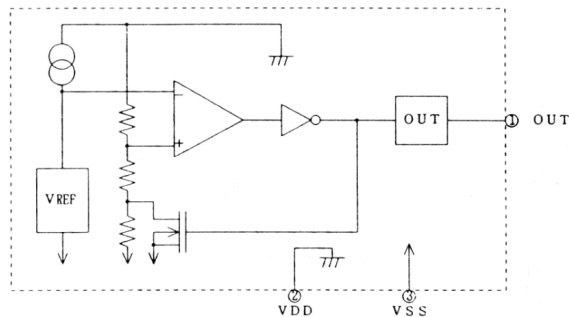

■ TC50H001F [TOSHIBA]
(Hex Buffer (TC4050 Type))

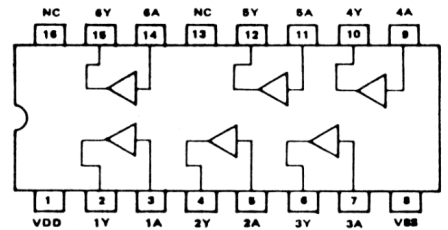

ct
ck
ta Input
ta Output

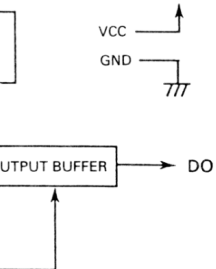

SECTION 2 EXPLODED VIEW AND PARTS LIST

2.1 REMOTE CONTROL ASSEMBLY M 1

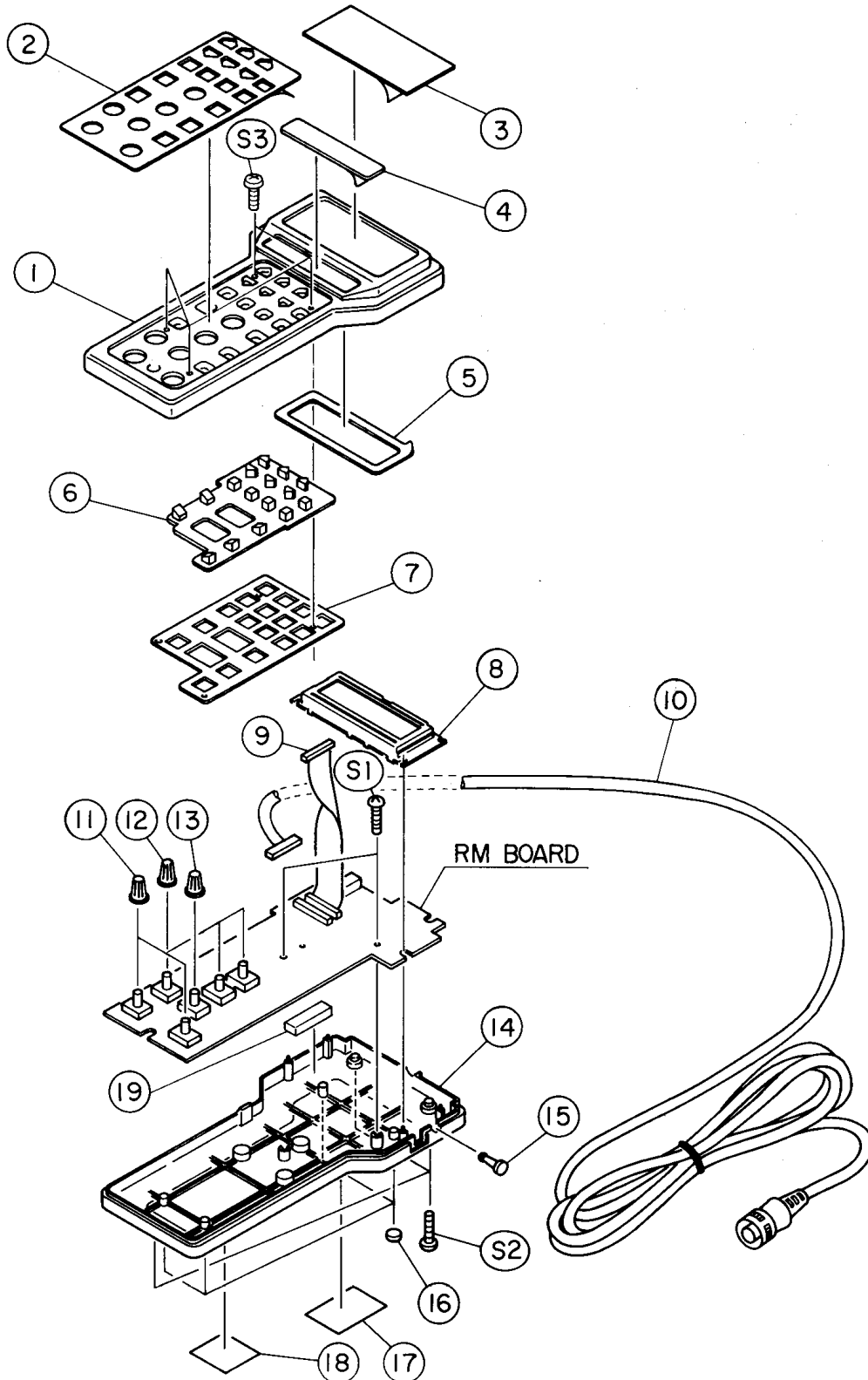

■ REMOTE CONTROL ASSEMBLY PARTS LIST **M1**

M1 **M** **M** **□** **□** **□** **□**

Symbol No.	Part No.	Part Name	Description
1	SC20540-001	UPPER CASE	
2	SC31791-001	SW SHEET	
3	SC45575-041	LCD SHEET	
4	SC45576-001	LED SHEET	
5	SC45574-00A	LCD CUSHION	
6	SC31790-001	KNOB SHEET	
7	SC45571-001	KNOB HOLDER	
8	LM162AT1	LCD MODULE	
9	SS34315-14-04	F.C.ASS'Y	
10	SCV2377-05A	DIN CABLE	5 m
11	SC45572-011	KNOB	LIGHT GRAY
12	SC45572-021	KNOB	RED
13	SC45572-031	KNOB	BLUE
14	SC20541-00A	BOTTOM CASE	
15	SS47923-002	BUSHING	
16	SS47949	FOOT	
17	SC45573-002	LABEL	
△ 18	—	SERIAL NO. PLATE	
19	SC45624-001	CUSHION	
S1	SBSF2606Z	SCREW	M2.6×6
S2	SBSF2608M	SCREW	M2.6×8
S3	SPSK2050M	SCREW	M2×5

SECTION 3 ELECTRICAL PARTS LIST

SAFETY PRECAUTION:

Parts identified by the Δ symbol are critical for safety. Replace only with specified parts numbers. For maximum reliability and performance, all other replacement parts should be identical to those specified.

NOTE:

- Parts not denoted by parts numbers are not supplied by JVC.
- Abbreviations in this list are as follows:

RESISTORS

In the "Description" column:

- All resistance values are in ohms (Ω).
- K expresses kilo-ohm (1 000 ohms, $k\Omega$).
- M expresses mega-ohm (10^6 ohms, $M\Omega$).

In the "Parts Name" column:

- COMP. RESISTOR : Composition Resistor
- U.F. RESISTOR : Non-inflammable Resistor
- O.M.F. RESISTOR : Oxide Metalized Film Resistor
- FUSI. RESISTOR : Fusible Resistor
- M.P. RESISTOR : Metal Plate Resistor
- M.G. RESISTOR : Metal Graze Resistor
- M.F. RESISTOR : Metal Film Resistor
- W.W. RESISTOR : Wire Wound Resistor

CAPACITORS

In the "Description" column:

- All capacitance values are in microfarad (μF) unless otherwise indicated.
- P expresses picofarad (10^{-12} farad, pF).

In the "Parts Name" column:

- TRIM. CAPACITOR : Trimmer Capacitor
- CER. CAPACITOR : Ceramic Capacitor
- E. CAPACITOR : Electrolytic Capacitor
- TAN. CAPACITOR : Tantalum Capacitor
- MPP CAPACITOR : Metalized Polypropylene Capacitor
- O.F. CAPACITOR : Oil Film Capacitor
- MPF CAPACITOR : Metalized Polyfilm Capacitor
- F.M. CAPACITOR : Film Mica Capacitor
- P.P. CAPACITOR : Polypropylene Capacitor
- P.S. CAPACITOR : Polystyrene Capacitor

Note: In the "Description" column of the parts list, (U) means the parts for the U version while (E) is for the E Version.

Symbol No.	Part No.	Part Name	Description
IC1	SCV1585-064	I.C.(M)	JVC (U)
	SCV1585-067	I.C.(M)	JVC (E)

← for U version
← for E version

3.1 RM BOARD ASSEMBLY LIST 01

<SCK2375-01-00A>

01□□□□□□

Symbol No.	Part No.	Part Name	Description
IC1	PLSC1086	I.C.(M)	MB89P718AHPF
IC2	S-2924AIF10	I.C.(M)	SEIKO
IC3	S-8054HNCB	I.C.(M)	SEIKO
IC4	TC50H001F	I.C.(M)	TOSHIBA
IC5	NJM78M05FA	I.C.(MONO-ANA)	JRC
IC6	S-2510A	I.C.(M)	
Q1	2SA1532(BC)	SI.TRANSISTOR	MATSUSHITA
Q2	2SA1532(BC)	SI.TRANSISTOR	MATSUSHITA
Q3	2SA1532(BC)	SI.TRANSISTOR	MATSUSHITA
Q4	DTC124EU	DIGI.TRANSISTOR	ROHM
Q5	DTC124EU	DIGI.TRANSISTOR	ROHM
Q6	DTC124EU	DIGI.TRANSISTOR	ROHM
Q7	DTC124EU	DIGI.TRANSISTOR	ROHM
Q8	DTC124EU	DIGI.TRANSISTOR	ROHM
Q9	DTC124EU	DIGI.TRANSISTOR	ROHM
Q10	2SB766(QR)	TRANSISTOR	MATSUSHITA
Q11	2SC1570NP(F)	SI.TRANSISTOR	SANYO
D1	MA143A	SI DIODE	MATSUSHITA
D2	MA143A	SI DIODE	MATSUSHITA
D3	MA143A	SI DIODE	MATSUSHITA
D4	HZM7.5NB2	ZENER DIODE	HITACHI
D5	MA143A	SI DIODE	MATSUSHITA
LD1	LN31GPH	L.E.D.	MATSUSHITA
LD2	LN81OPH(S)	L.E.D.	MATSUSHITA
LD3	LN81OPH(S)	L.E.D.	MATSUSHITA
LD4	LN81OPH(S)	L.E.D.	MATSUSHITA
LD5	LN81OPH(S)	L.E.D.	MATSUSHITA
R1	NRSA02J-101	M.G.RESISTOR	100 1/10W
R2	NRSA02J-222	M.G.RESISTOR	2.2K 1/10W
R3	NRSA02J-223	M.G.RESISTOR	22K 1/10W
R4	NRSA02J-101	M.G.RESISTOR	100 1/10W
R5	NRSA02J-104	M.G.RESISTOR	100K 1/10W
R6	NRSA02J-222	M.G.RESISTOR	2.2K 1/10W
R7	NRSA02J-101	M.G.RESISTOR	100 1/10W
R8	NRSA02J-222	M.G.RESISTOR	2.2K 1/10W
R9	NRSA02J-223	M.G.RESISTOR	22K 1/10W
R10	NRSA02J-821	M.G.RESISTOR	820 1/10W
R11	NRSA02J-821	M.G.RESISTOR	820 1/10W
R12	NRSA02J-821	M.G.RESISTOR	820 1/10W
R13	NRSA02J-821	M.G.RESISTOR	820 1/10W
R14	NRSA02J-821	M.G.RESISTOR	820 1/10W
R15	NRSA02J-472	M.G.RESISTOR	4.7K 1/10W
R16	NRSA02J-472	M.G.RESISTOR	4.7K 1/10W
R17	NRSA02J-472	M.G.RESISTOR	4.7K 1/10W
R18	NRSA02J-472	M.G.RESISTOR	4.7K 1/10W
R19	NRSA02J-472	M.G.RESISTOR	4.7K 1/10W
R20	NRSA02J-472	M.G.RESISTOR	4.7K 1/10W
R21	NRSA02J-472	M.G.RESISTOR	4.7K 1/10W
R22	NRSA02J-472	M.G.RESISTOR	4.7K 1/10W
R23	NRSA02J-472	M.G.RESISTOR	4.7K 1/10W
R24	NRSA02J-472	M.G.RESISTOR	4.7K 1/10W
R25	NRSA02J-472	M.G.RESISTOR	4.7K 1/10W
R26	NRSA02J-472	M.G.RESISTOR	4.7K 1/10W
R27	NRSA02J-472	M.G.RESISTOR	4.7K 1/10W

Symbol No.	Part No.	Part Name	Description
R28	NRSA02J-472	M.G.RESISTOR	4.7K 1/10W
R29	NRSA02J-472	M.G.RESISTOR	4.7K 1/10W
R30	NRSA02J-472	M.G.RESISTOR	4.7K 1/10W
R31	NRSA02J-472	M.G.RESISTOR	4.7K 1/10W
R32	NRSA02J-223	M.G.RESISTOR	22K 1/10W
R33	NRSA02J-104	M.G.RESISTOR	100K 1/10W
R34	NRSA02J-562	M.G.RESISTOR	5.6K 1/10W
R35	NRSA02J-332	M.G.RESISTOR	3.3K 1/10W
R36	NRSA02J-103	M.G.RESISTOR	10K 1/10W
R37	NRSA02J-472	M.G.RESISTOR	4.7K 1/10W
R38	NRSA02J-101	M.G.RESISTOR	100 1/10W
R39	NRSA02J-101	M.G.RESISTOR	100 1/10W
R40	NRSA02J-101	M.G.RESISTOR	100 1/10W
R41	NRSA02J-101	M.G.RESISTOR	100 1/10W
R42	NRSA02J-101	M.G.RESISTOR	100 1/10W
R43	NRSA02J-101	M.G.RESISTOR	100 1/10W
R44	NRSA02J-101	M.G.RESISTOR	100 1/10W
R45	NRSA02J-223	M.G.RESISTOR	22K 1/10W
R46	NRSA02J-220	M.G.RESISTOR	22 1/10W
R47	NRSA02J-220	M.G.RESISTOR	22 1/10W
R48	NRSA02J-562	M.G.RESISTOR	5.6K 1/10W
R49	NRSA02J-OR0	M.G.RESISTOR	0 1/10W
VR1	QVGA14B-S14	TRIM.RESISTOR	10K IRIS
VR2	QVGA14B-S14	TRIM.RESISTOR	10K M.BLACK
VR3	QVGA14B-S14	TRIM.RESISTOR	10K PAINT R
VR4	QVGA14B-S14	TRIM.RESISTOR	10K PAINT B
VR5	QVGA14B-S14	TRIM.RESISTOR	10K FOCUS SPEED
VR6	QVGA14B-S14	TRIM.RESISTOR	10K ZOOM SPEED
VR7	QVPB612-202	VR	2.0K CONTRAST
C1	QEX41CM-156	E.CAPACITOR	15 16V
C2	NCF21EZ-104	CER.CAPACITOR	0.10 25V
C3	QEX41AK-226	E.CAPACITOR	22 10V
C4	NEF11AM-156	TAN.CAPACITOR	15 10V
C5	NCF21EZ-104	CER.CAPACITOR	0.10 25V
C6	NCF21EZ-104	CER.CAPACITOR	0.10 25V
C7	NCF21EZ-104	CER.CAPACITOR	0.10 25V
C8	NCF21EZ-104	CER.CAPACITOR	0.10 25V
C9	NCF21EZ-104	CER.CAPACITOR	0.10 25V
C10	NCF21EZ-104	CER.CAPACITOR	0.10 25V
C11	NCF21EZ-104	CER.CAPACITOR	0.10 25V
C12	NCF21EZ-104	CER.CAPACITOR	0.10 25V
C13	QER40JM-107	E.CAPACITOR	100 6.3V
C14	NCF21EZ-104	CER.CAPACITOR	0.10 25V
C15	NCF21EZ-104	CER.CAPACITOR	0.10 25V
C16	NCF21EZ-104	CER.CAPACITOR	0.10 25V
C17	QE20171-224	E.CAPACITOR	0.22
C18	NCF21EZ-104	CER.CAPACITOR	0.10 25V
C20	NCT03CH-220	CER.CAPACITOR	22P 50V
C21	NCT03CH-220	CER.CAPACITOR	22P 50V
L1	SMV2223	PEAKING COIL	10μH
LC1	SCV1804-222	EMI FILTER	
LC2	SCV1804-222	EMI FILTER	
LC3	SCV1804-222	EMI FILTER	
LC4	SCV1804-222	EMI FILTER	

Symbol No.	Part No.	Part Name	Description
X1	SCV1492-001	CRYSTAL	7.373MHz
S1	QSS1A22-S03	SLIDE SWITCH	OPERATE
S2	SCV1639-001	PUSH SWITCH	MENU UP
S3	SCV1639-001	PUSH SWITCH	MENU DOWN
S4	SCV1639-001	PUSH SWITCH	FUNC1 UP
S5	SCV1639-001	PUSH SWITCH	FUNC1 DOWN
S6	SCV1639-001	PUSH SWITCH	FUNC2 UP
S7	SCV1639-001	PUSH SWITCH	FUNC2 DOWN
S8	SCV1639-001	PUSH SWITCH	IRIS AUTO
S9	SCV1639-001	PUSH SWITCH	NEAR
S10	SCV1639-001	PUSH SWITCH	FAR
S11	SCV1639-001	PUSH SWITCH	WIDE
S12	SCV1639-001	PUSH SWITCH	TELE
S13	SCV1639-001	PUSH SWITCH	GAIN
S14	SCV1639-001	PUSH SWITCH	SET
S15	SCV1639-001	PUSH SWITCH	SHUTTER
S16	SCV1639-001	PUSH SWITCH	W.BAL
S17	SCV1639-001	PUSH SWITCH	FILE
CN1	SSV1591-L06	CONNECTOR	6-PIN
CN2	SSV2120-S14	CONNECTOR	14-PIN
CN3	SSV1591-L02	CONNECTOR	2-PIN
TP1	SCV1880-001	TEST POINT	
TP2	SCV1880-001	TEST POINT	
TP3	SCV1880-001	TEST POINT	

SECTION 4 REPACKING

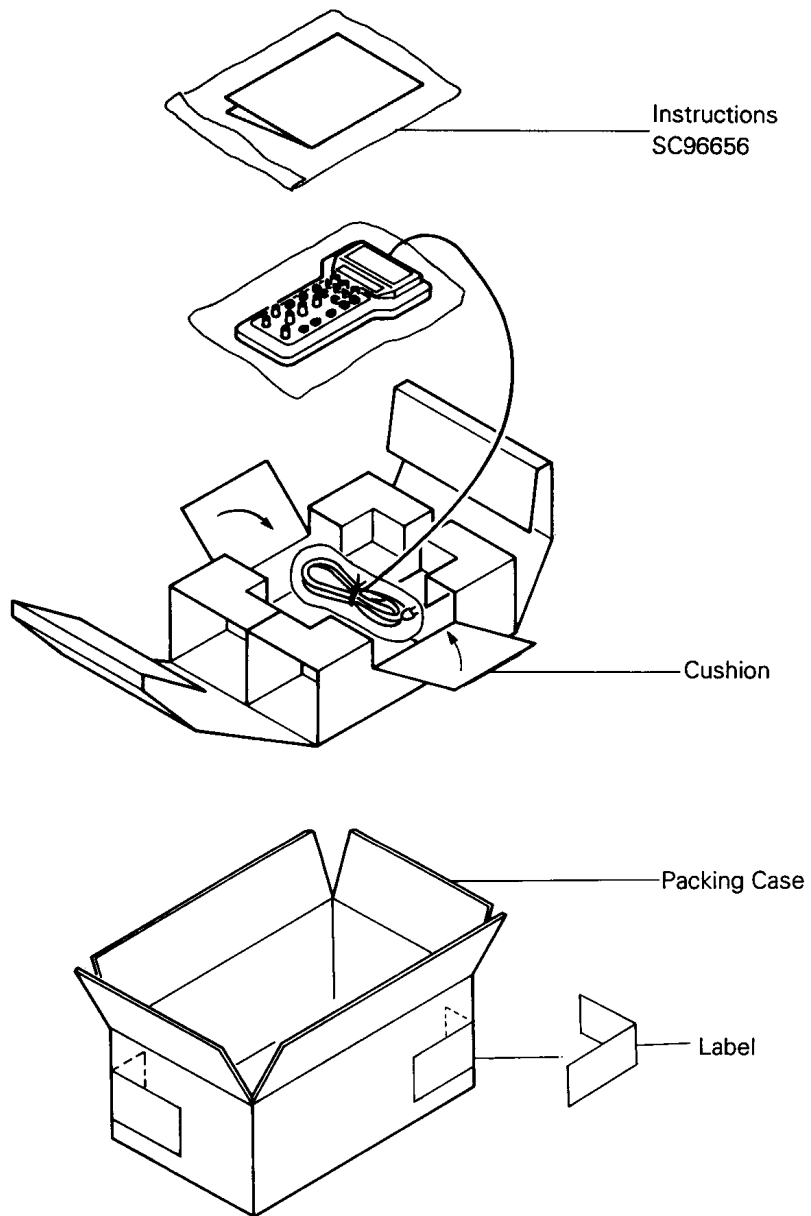

Note: Accessories above are subject to change without notice.

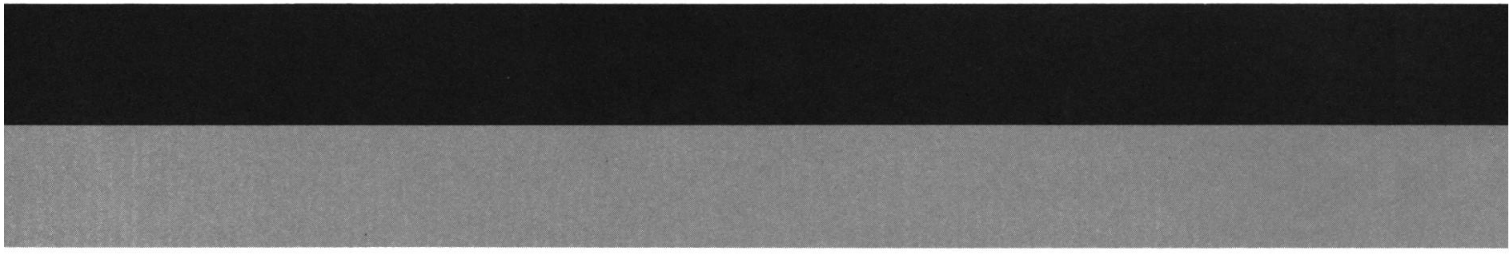

JVC

VICTOR COMPANY OF JAPAN, LIMITED